

WARNING: Read these material prior to assembling this trampoline and enclosure.



NORTH TRAMPOLINE

ASSEMBLY MANUAL

RECTANGULAR | 17,5x12

NTC715325-35 : Rectangular 17,5x12 Black

This assembly manual contains instructions for the North Trampoline Rectangular trampoline.

NTM100028 / Version 1





NORTH TRAMPOLINE

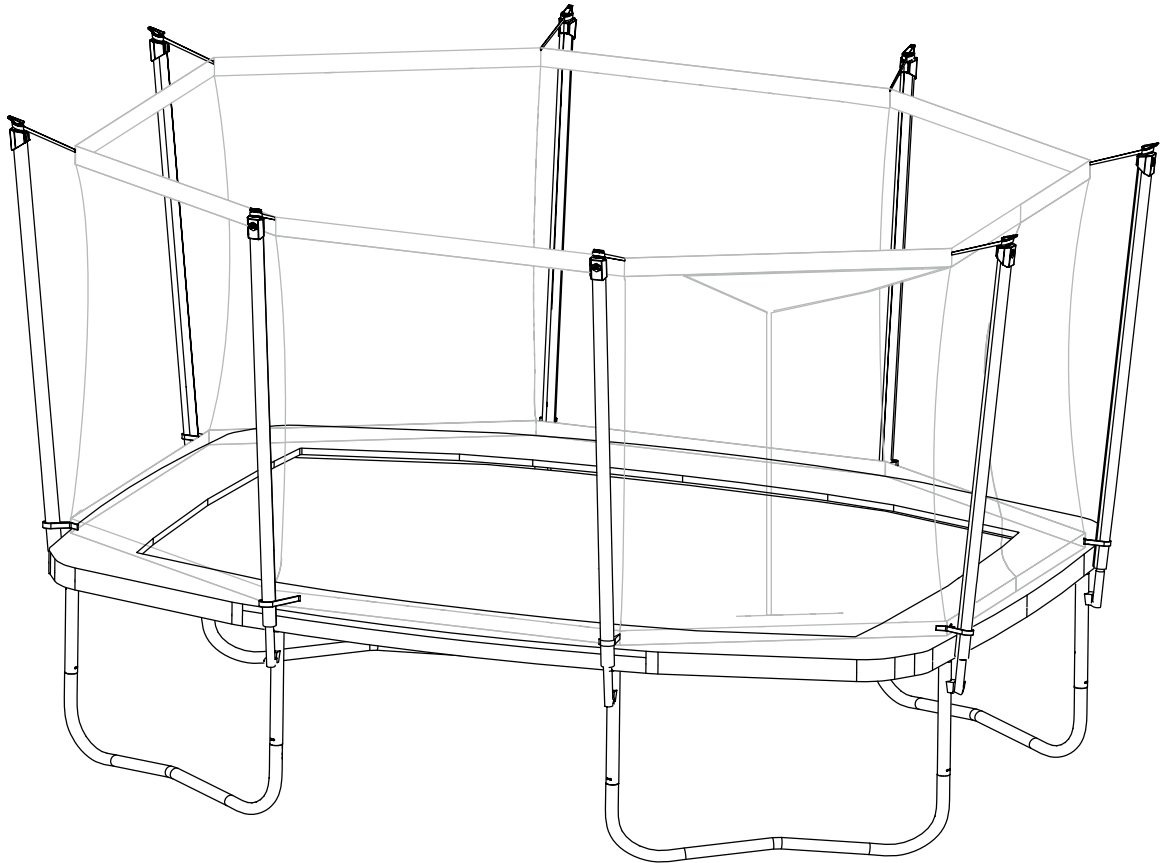

RECTANGULAR | 17,5x12ft

This assembly manual contains important information.

Read carefully. Keep for future reference.

All rights reserved 2026. North Trampoline INC ©
All artwork and illustrations are owned by North Trampoline INC, USA.

ASSEMBLY INSTRUCTIONS

ASSEMBLY

The trampoline is to be assembled in accordance with the instruction manual by two or three persons of which one should be an adult. Use gloves to protect hands and fingers from injury during assembly.

Any modifications made by the consumer to the original trampoline (e.g. the adding of an accessory) shall be carried out according to the instructions of the manufacturer.

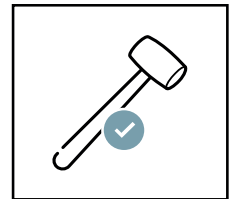
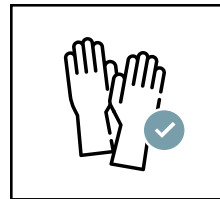
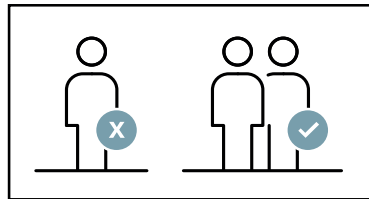

TRAMPOLINE PLACEMENT

Adequate overhead clearance is essential. A minimum of 24 ft from ground level is recommended. Provide clearance for wires, tree limbs, and other possible hazards.

Lateral clearance is essential. Place the trampoline and trampoline enclosure away from walls, structures, fences, and other play areas. Maintain a clear space on all sides of the trampoline and trampoline enclosure.

Place the trampoline and trampoline enclosure on a level surface before use.

**TRAMPOLINE
PLACEMENT** cont.

Use the trampoline and trampoline enclosure in a well-lit area. Artificial illumination may be required for indoor or shady areas.

Secure the trampoline and trampoline enclosure against unauthorized and unsupervised use.

Remove any obstructions from beneath the trampoline and trampoline enclosure.

The owner and supervisors of the trampoline are responsible to make all users aware of practices specified in the use instructions.

The trampoline enclosure is only to be used as an enclosure for a trampoline of a size for which the enclosure is designed.

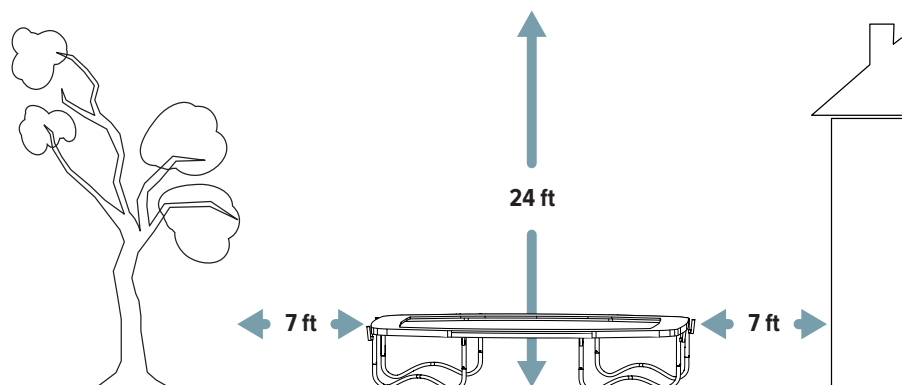

PARTS LIST

This is a parts list for your trampoline. If you find any piece missing please contact your local dealer.

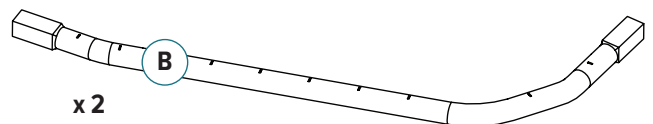
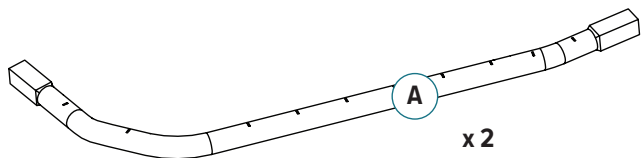
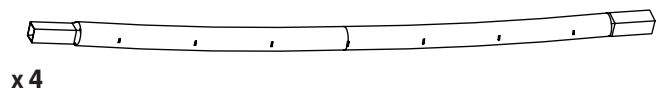
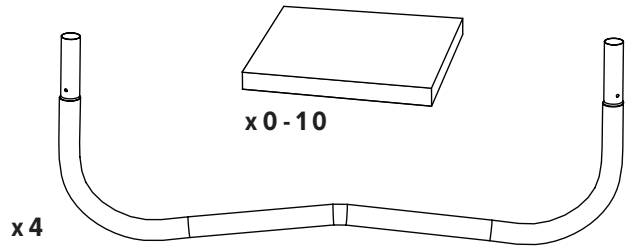
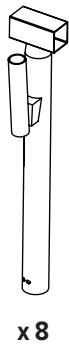
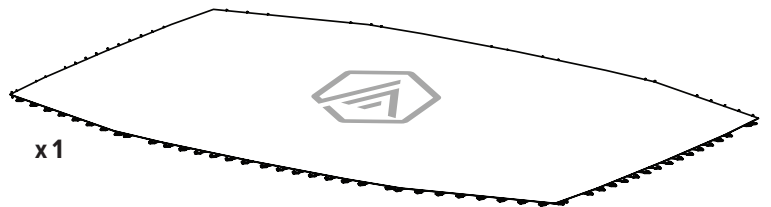
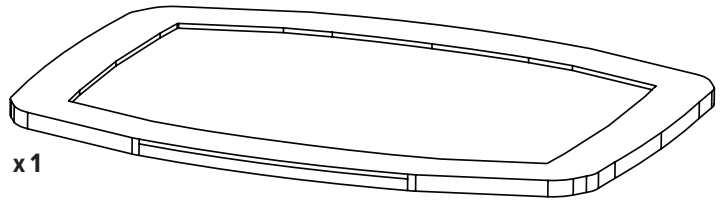
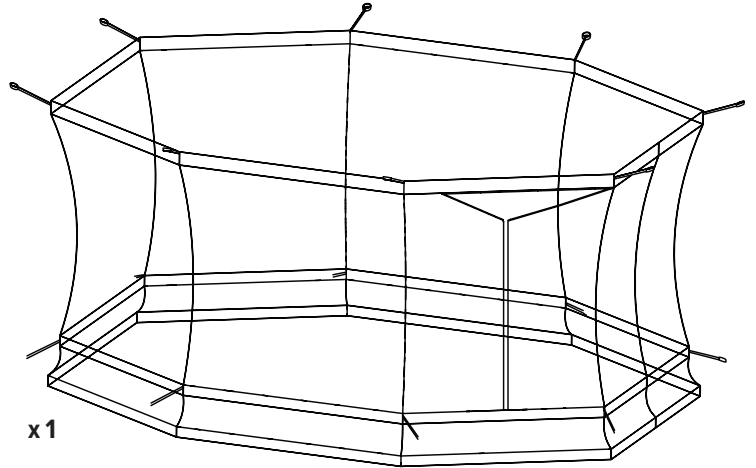
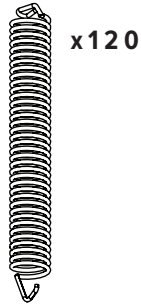
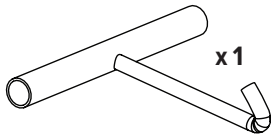

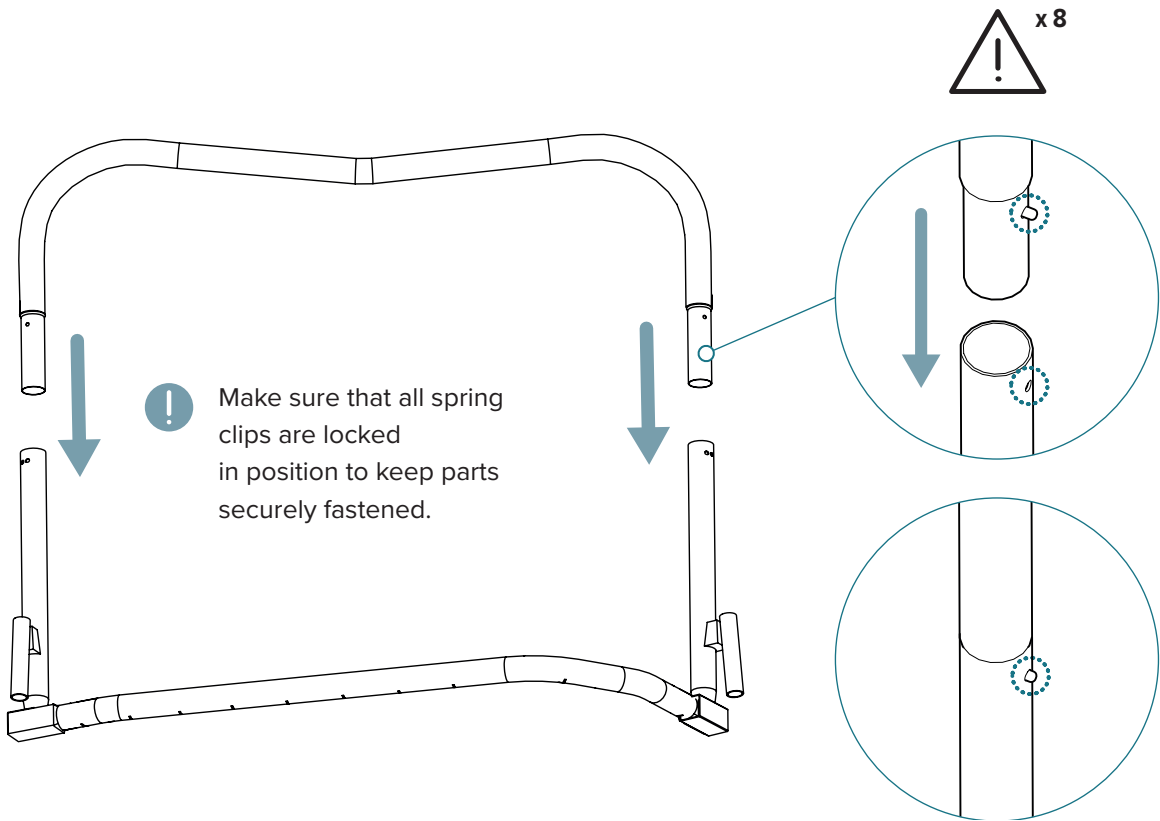
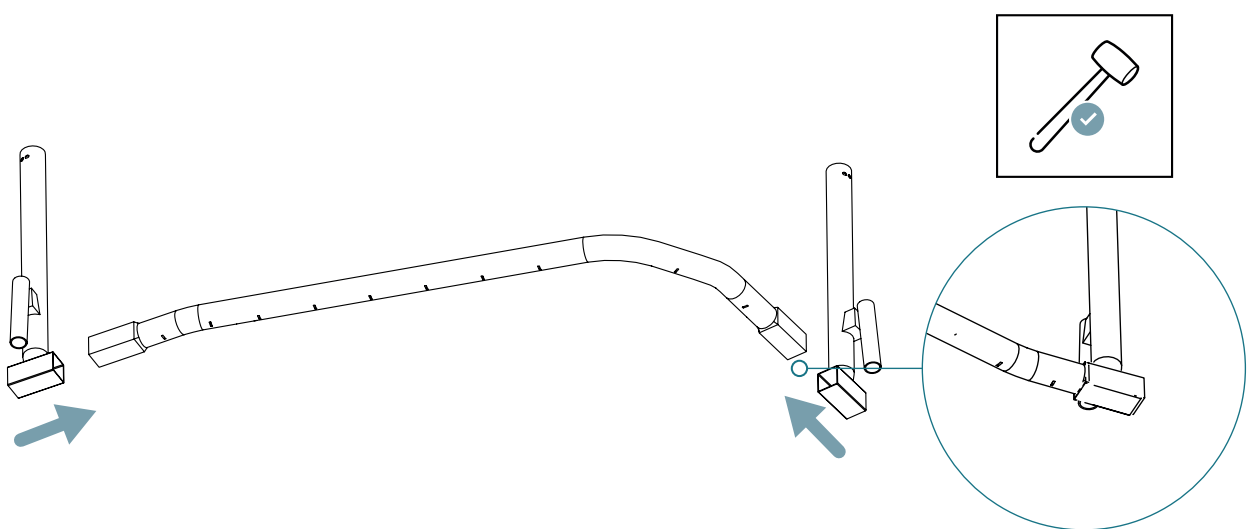
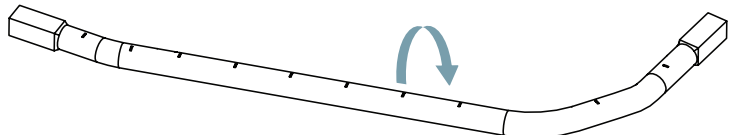
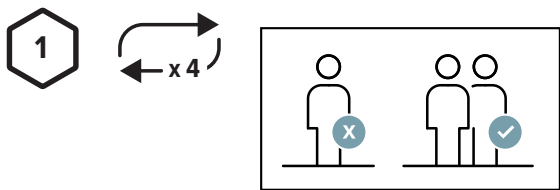

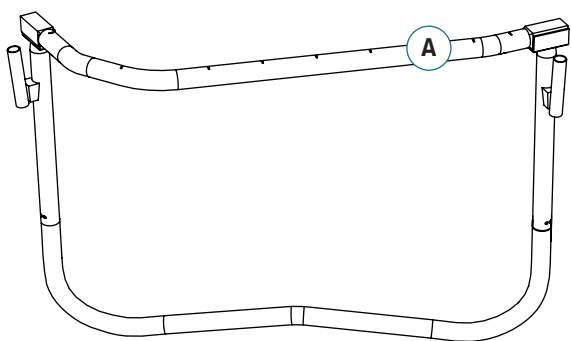
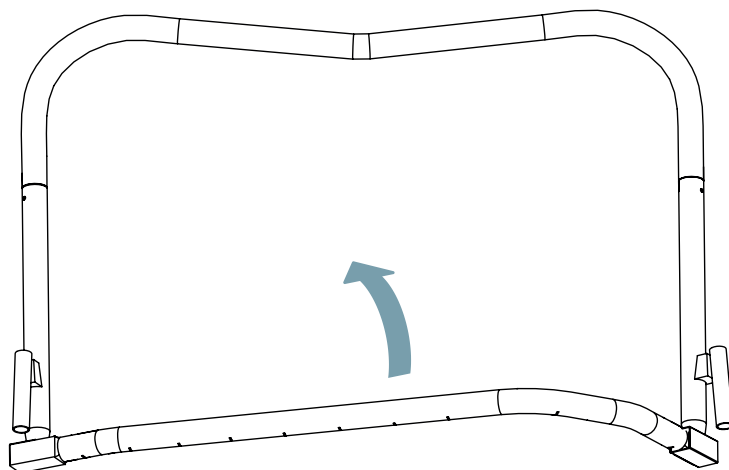

x2

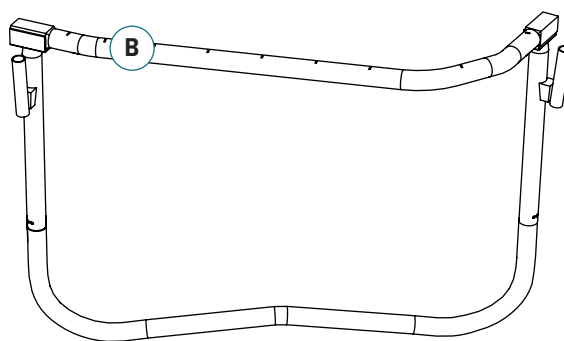

x2

2

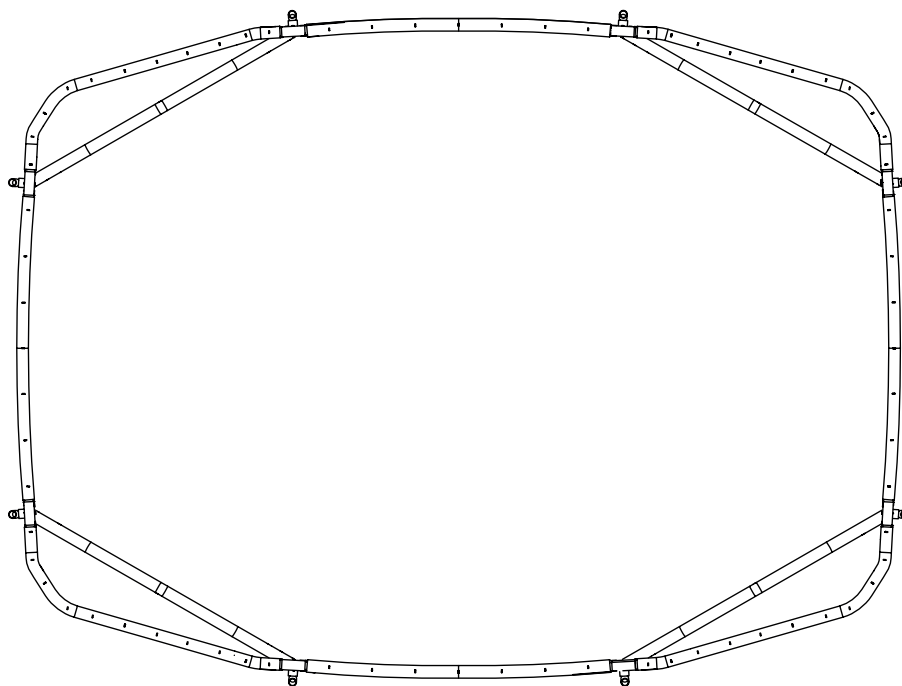
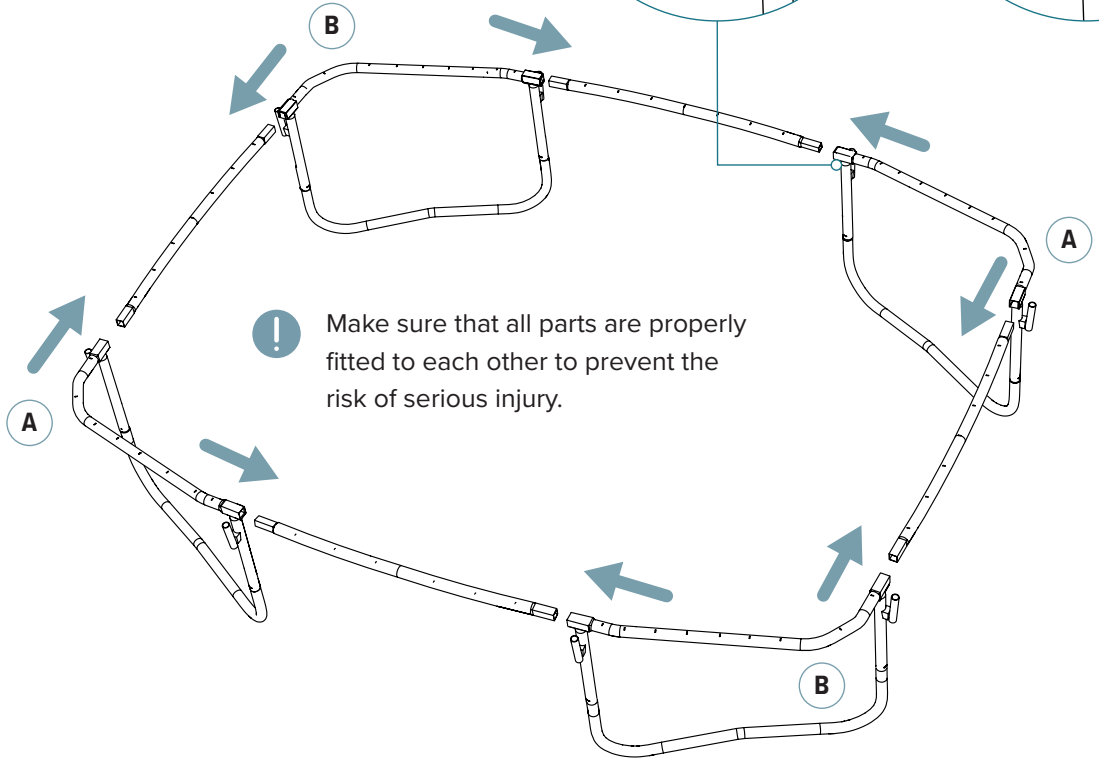
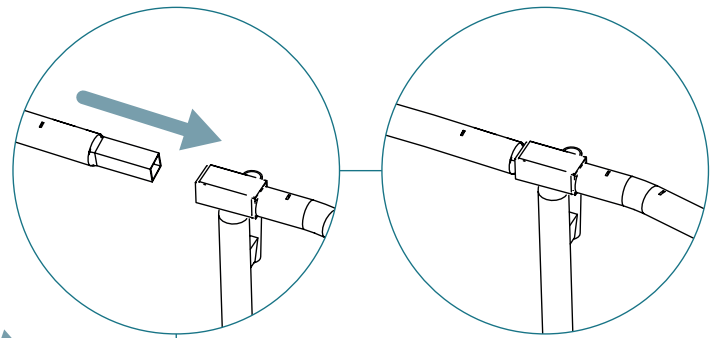
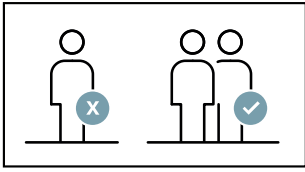

3

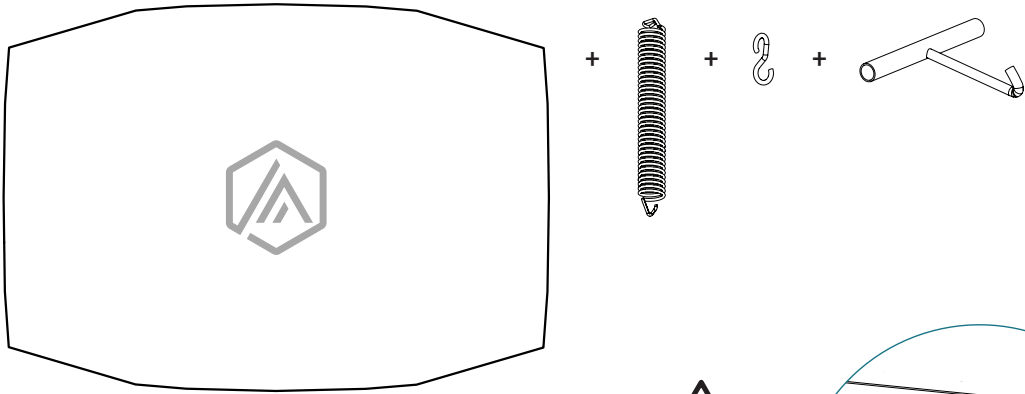

! Always use the spring tool when installing and removing springs to prevent injuries.

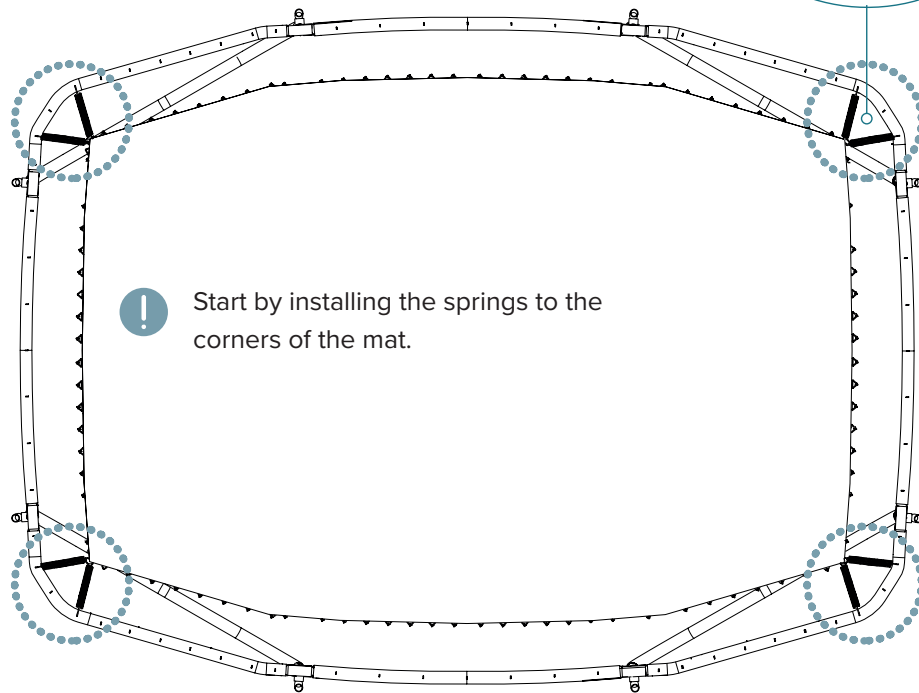
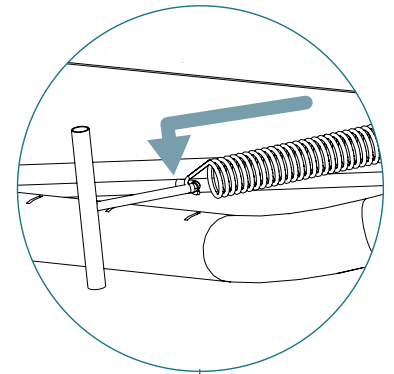

! Start by installing the springs to the corners of the mat.

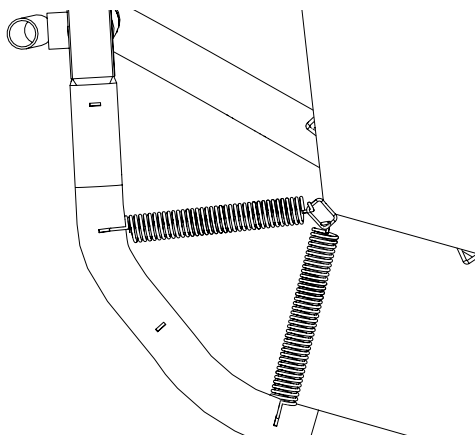

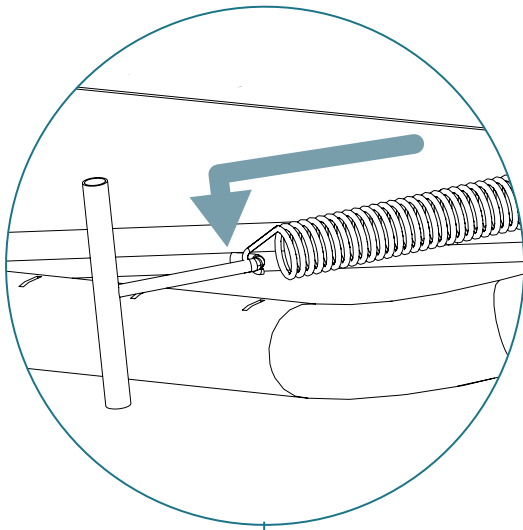

! Always use the spring tool when installing and removing springs to prevent injuries.

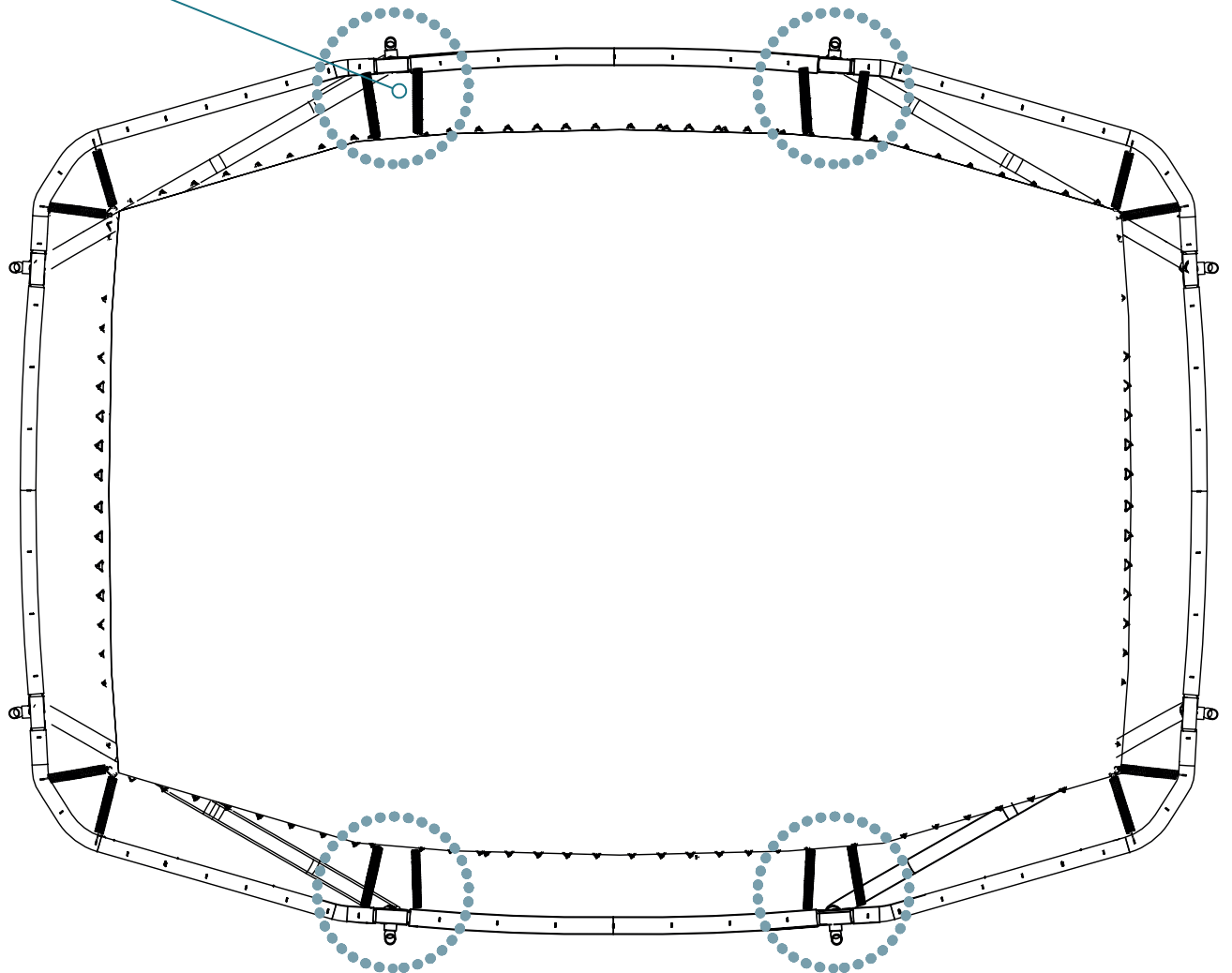

4

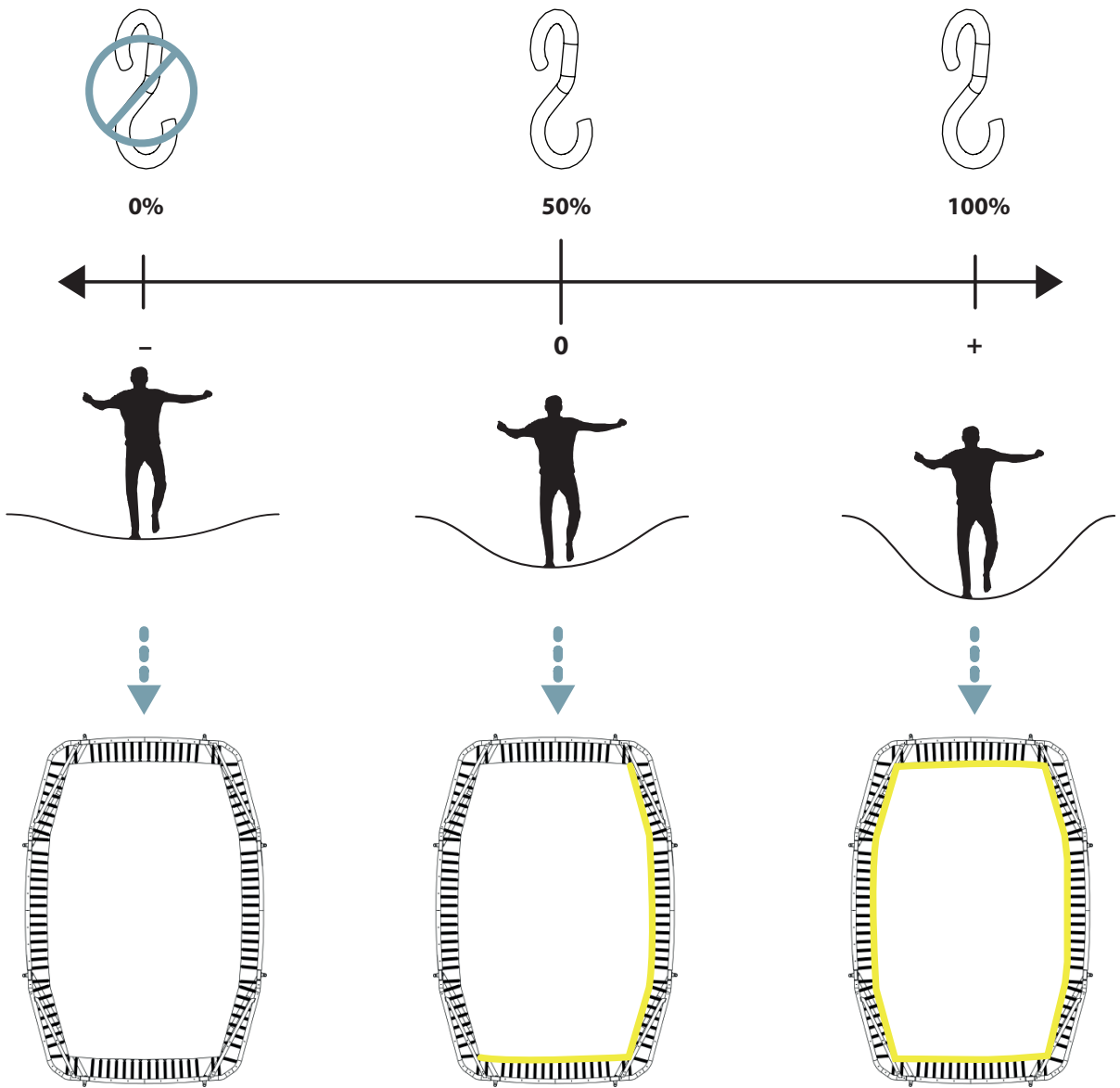

! By adding more extension hooks to the springs the trampoline becomes softer - with fewer or no extension hooks the trampoline becomes harder.

! Extension hooks on 2 sides for medium bounce.

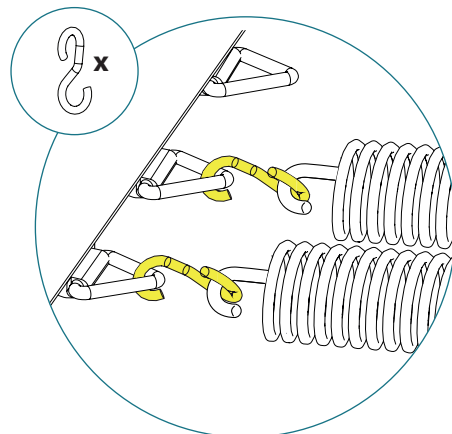
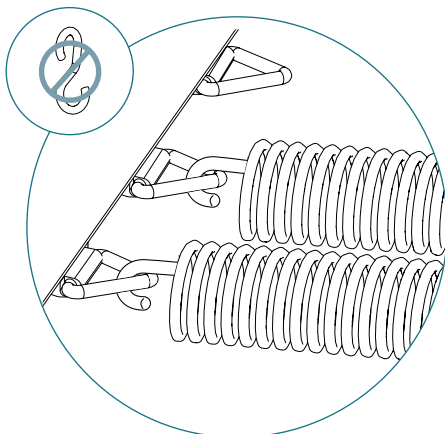

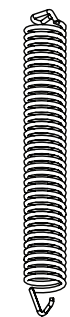

120

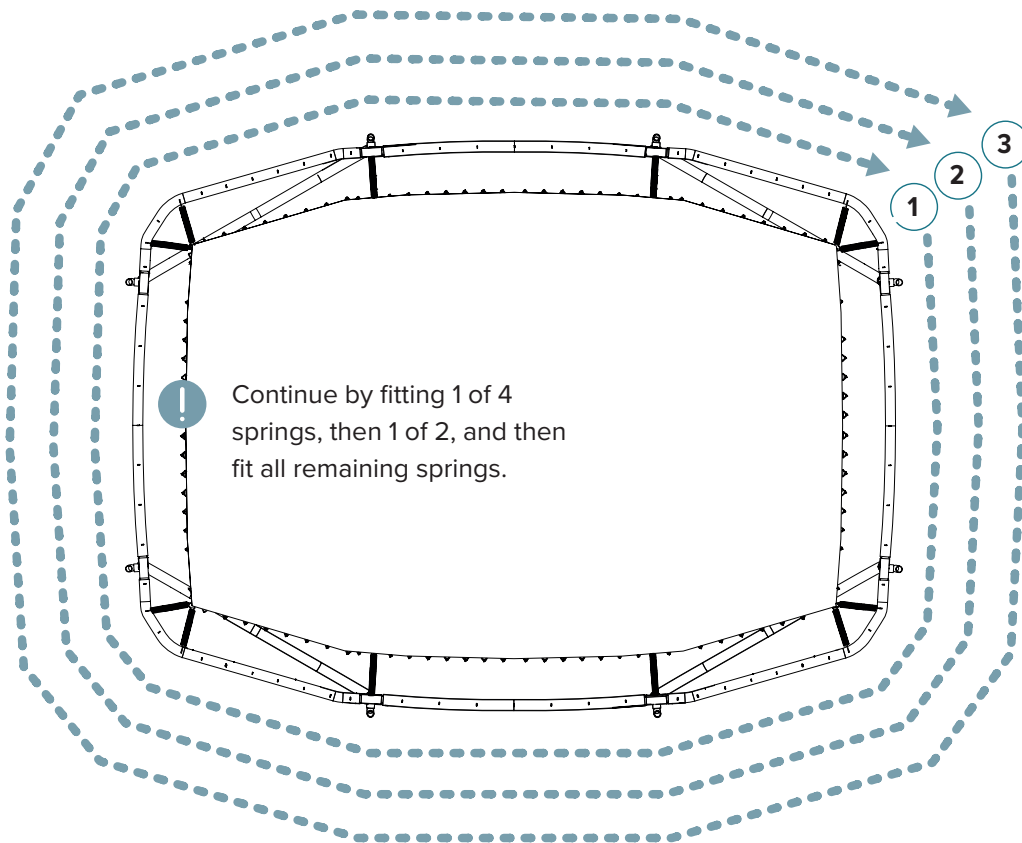

Continue by fitting 1 of 4 springs, then 1 of 2, and then fit all remaining springs.

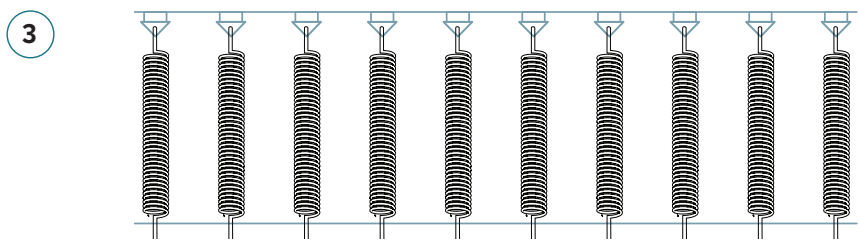
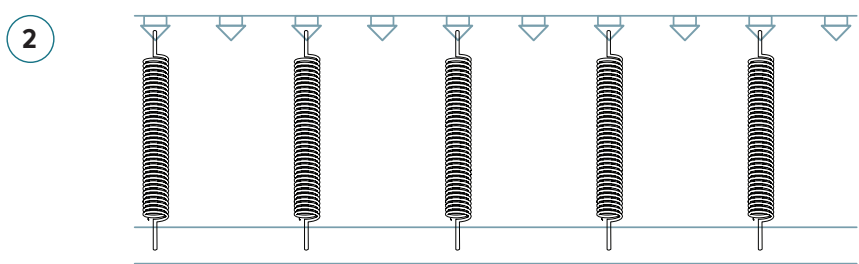
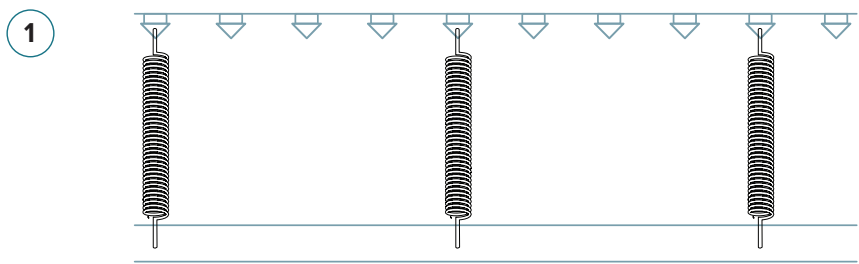

5



x 4

! Do not dispose the padding foam.

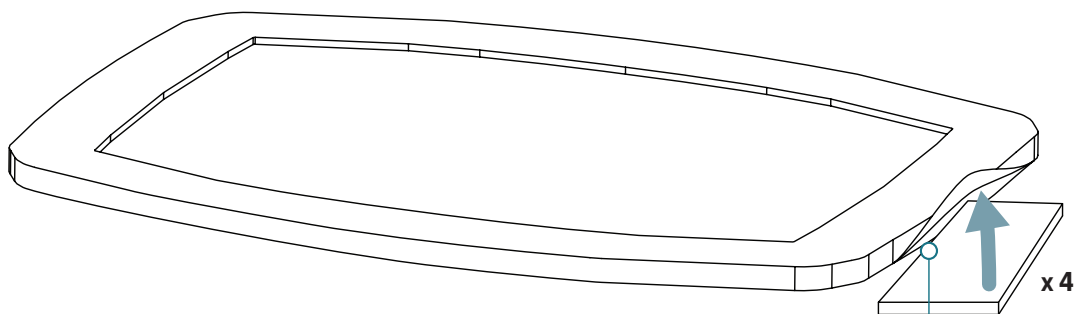

! Fit the foam pieces into the matching pockets of the protective padding. Close the zipper securely.

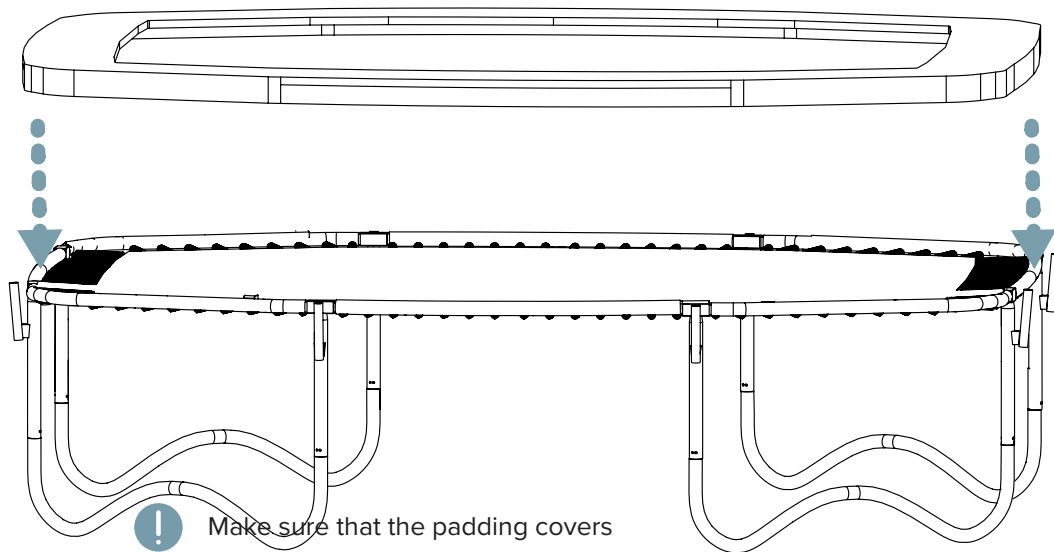
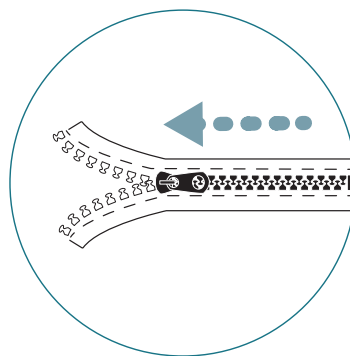

! Make sure that the padding covers the frame on all sides.

! Close the safety zipper between the bed and padding.

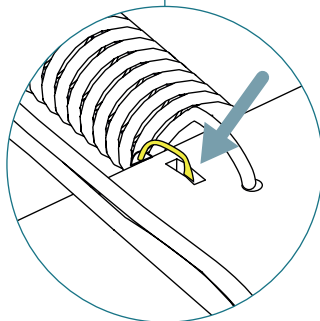
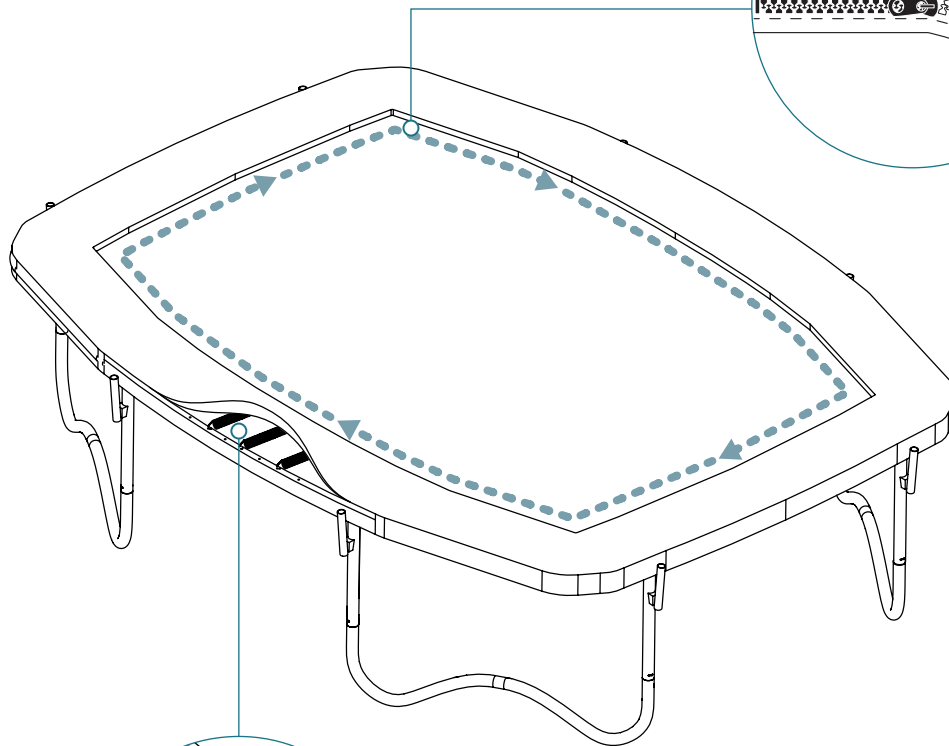
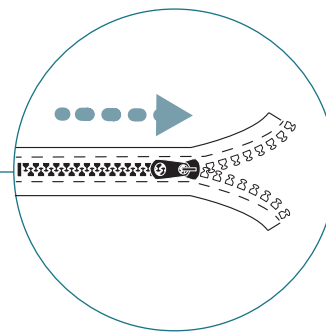

! Fit the elastic strings to the loops under the padding. Make sure they are securely attached.

! Fit all the elastic straps from the protective padding to the frame to keep the padding in place on top of the frame. This is very important to prevent accidents and serious injuries.

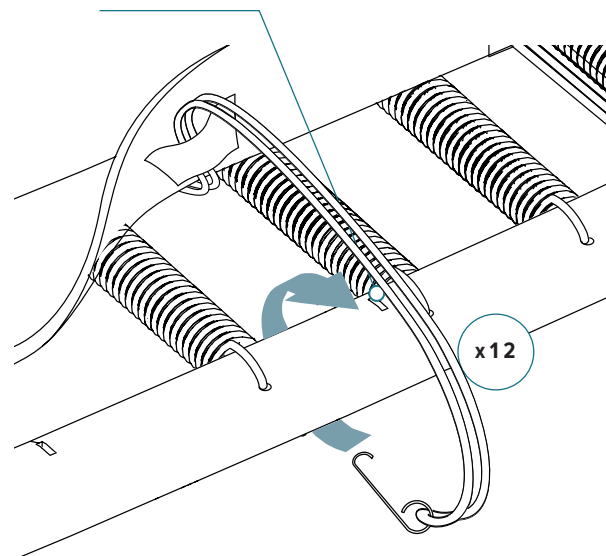
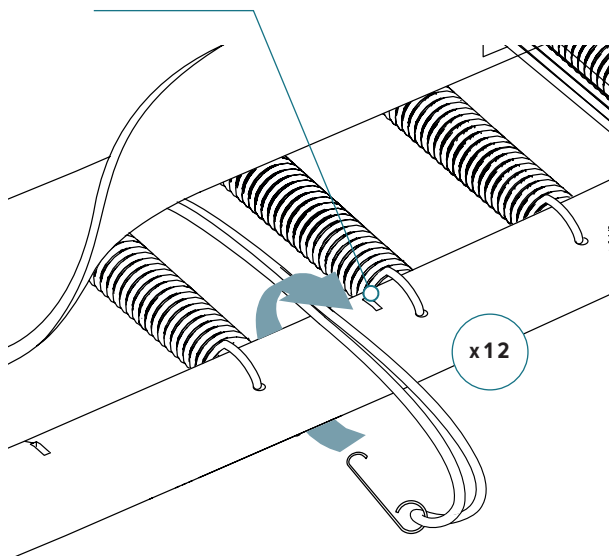

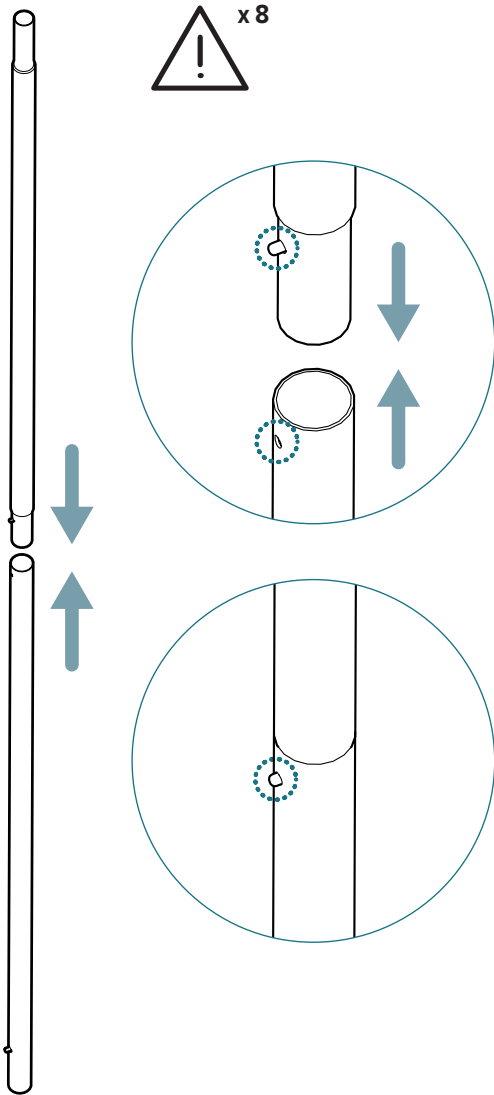

! Fit the plastic top cap on the poles and make sure that all spring clips are locked in position to keep parts securely fastened.

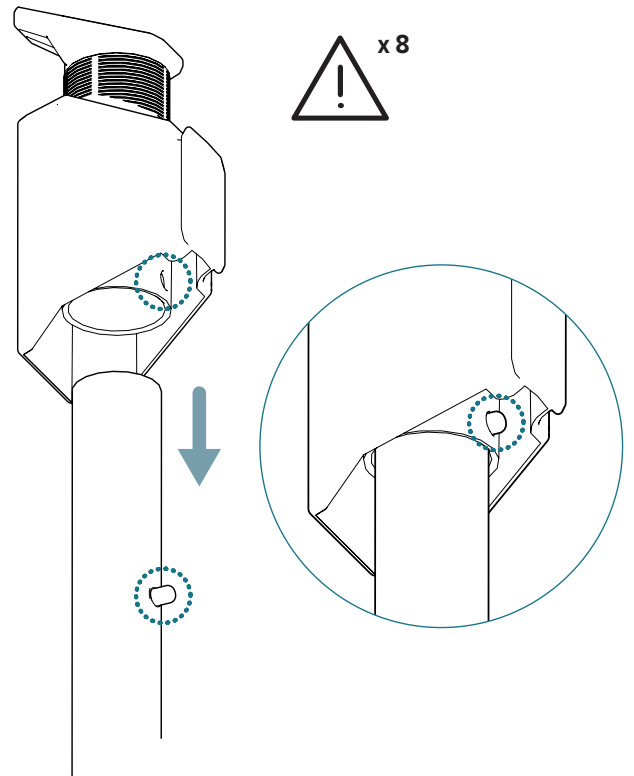

! Connect the upper and lower part of the safety net poles. Make sure that all the spring clips are locked into position to keep the poles securely connected. Cover the poles with foam.

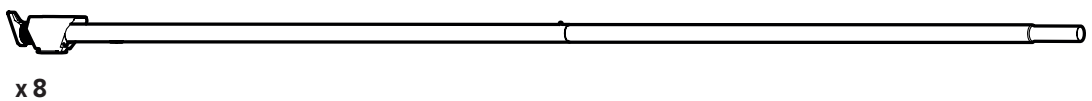

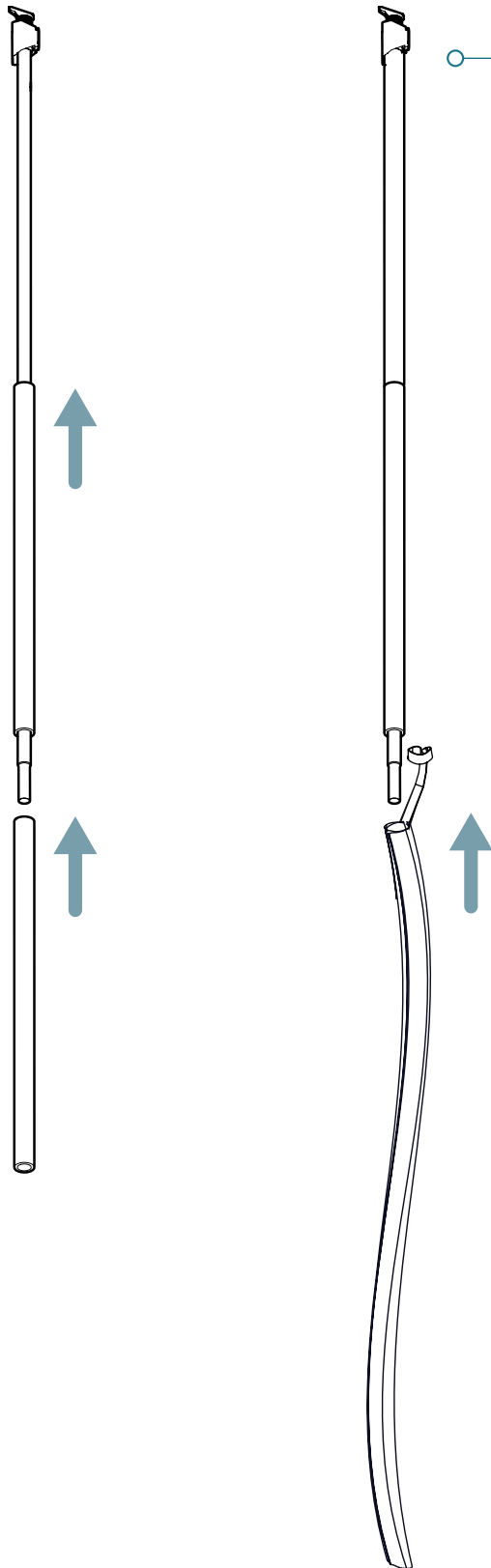

! Fit the loop around the hook on the top cap.

! Fit the black PVC sleeves over the protective foam on the safety net poles.

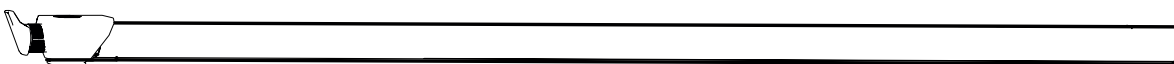

x8

7

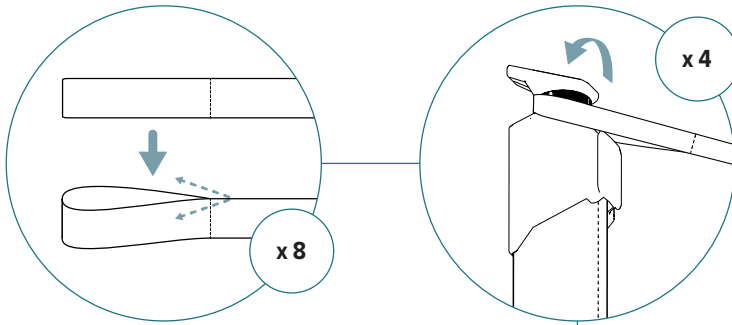

! Fit the net loops onto the top caps and place the safety net poles on the frame. Follow the order below.

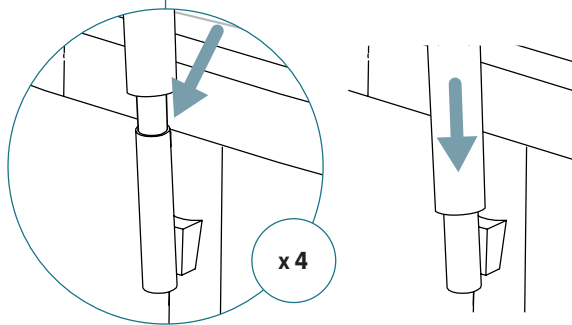
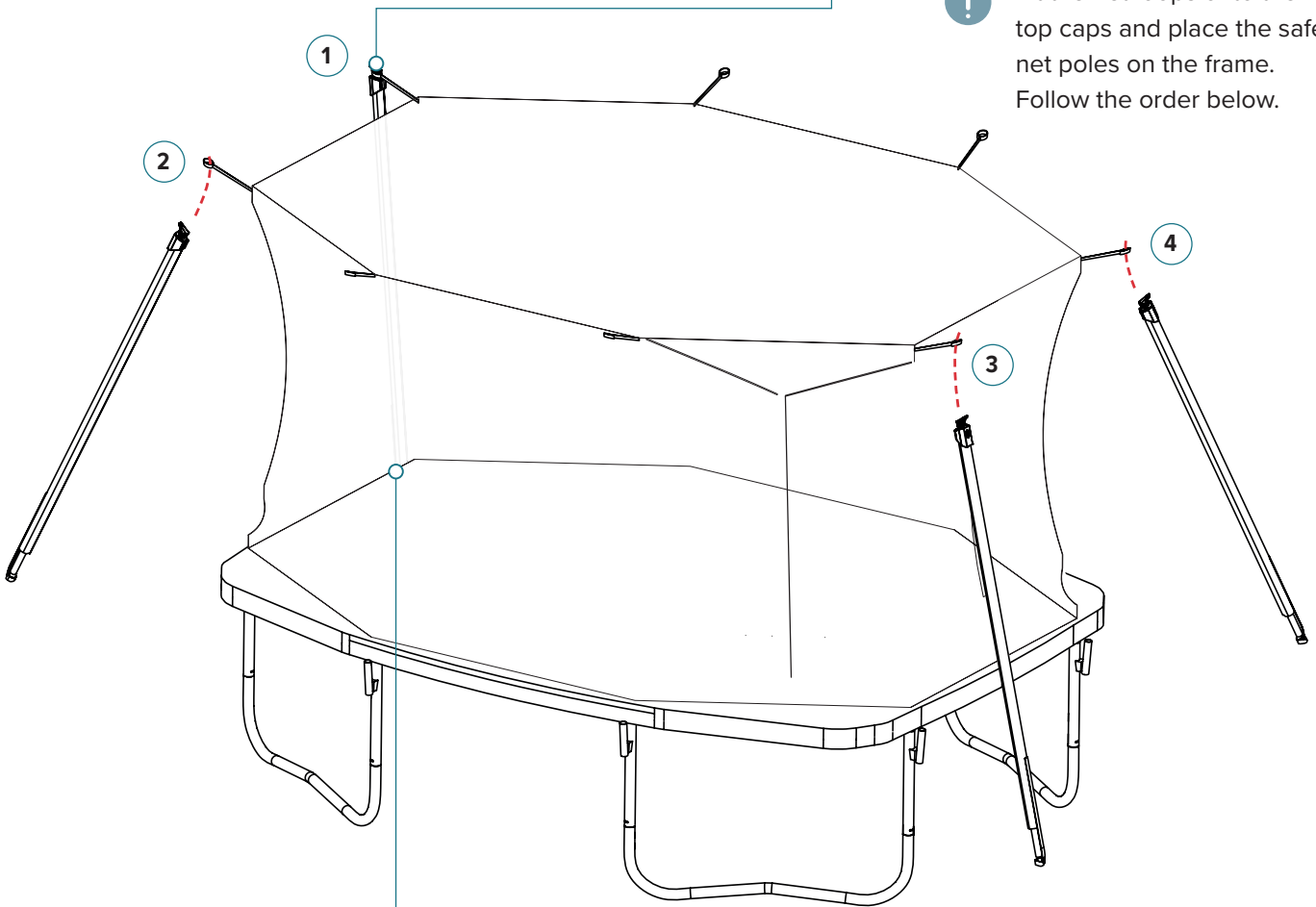

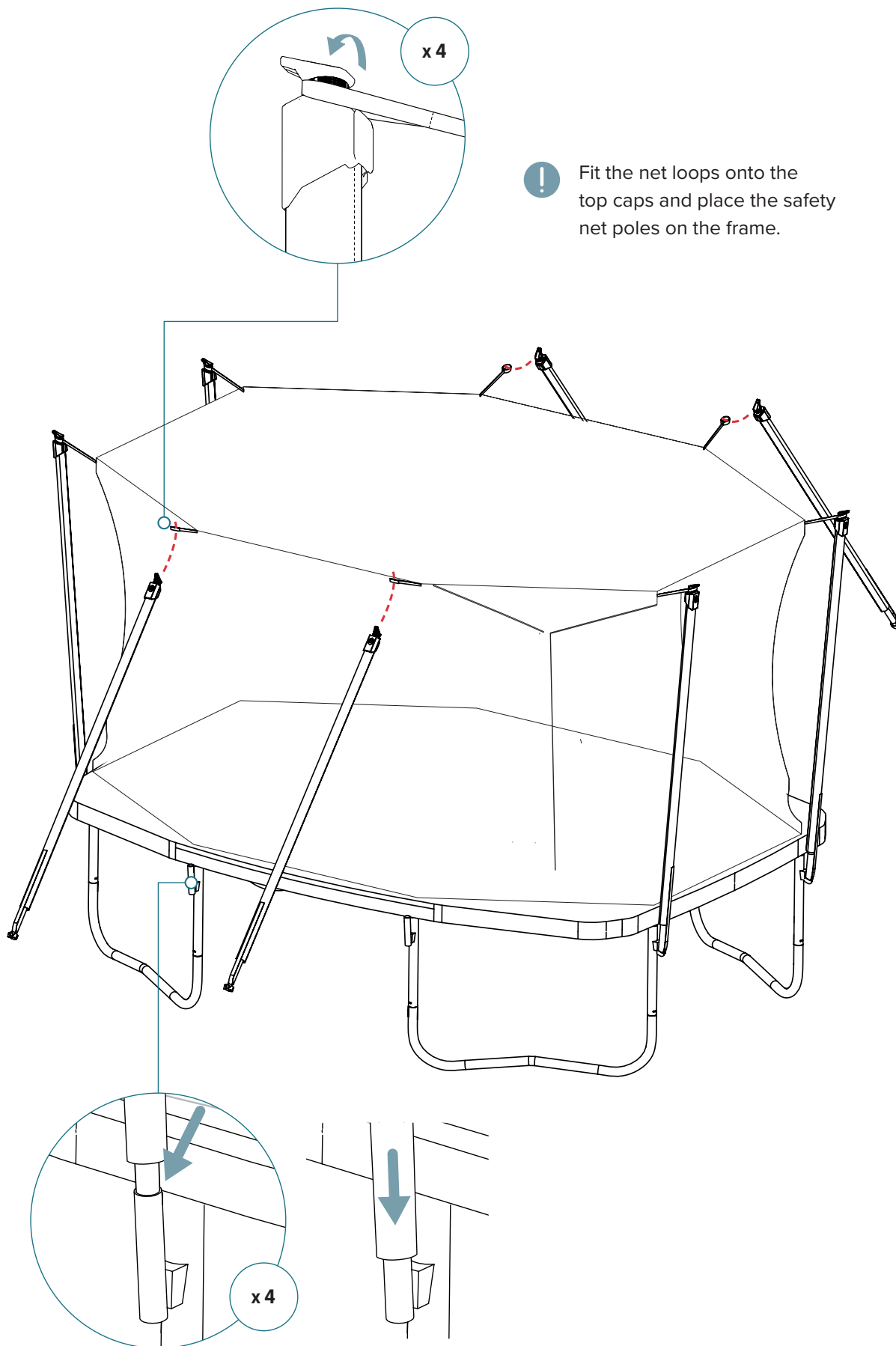

8

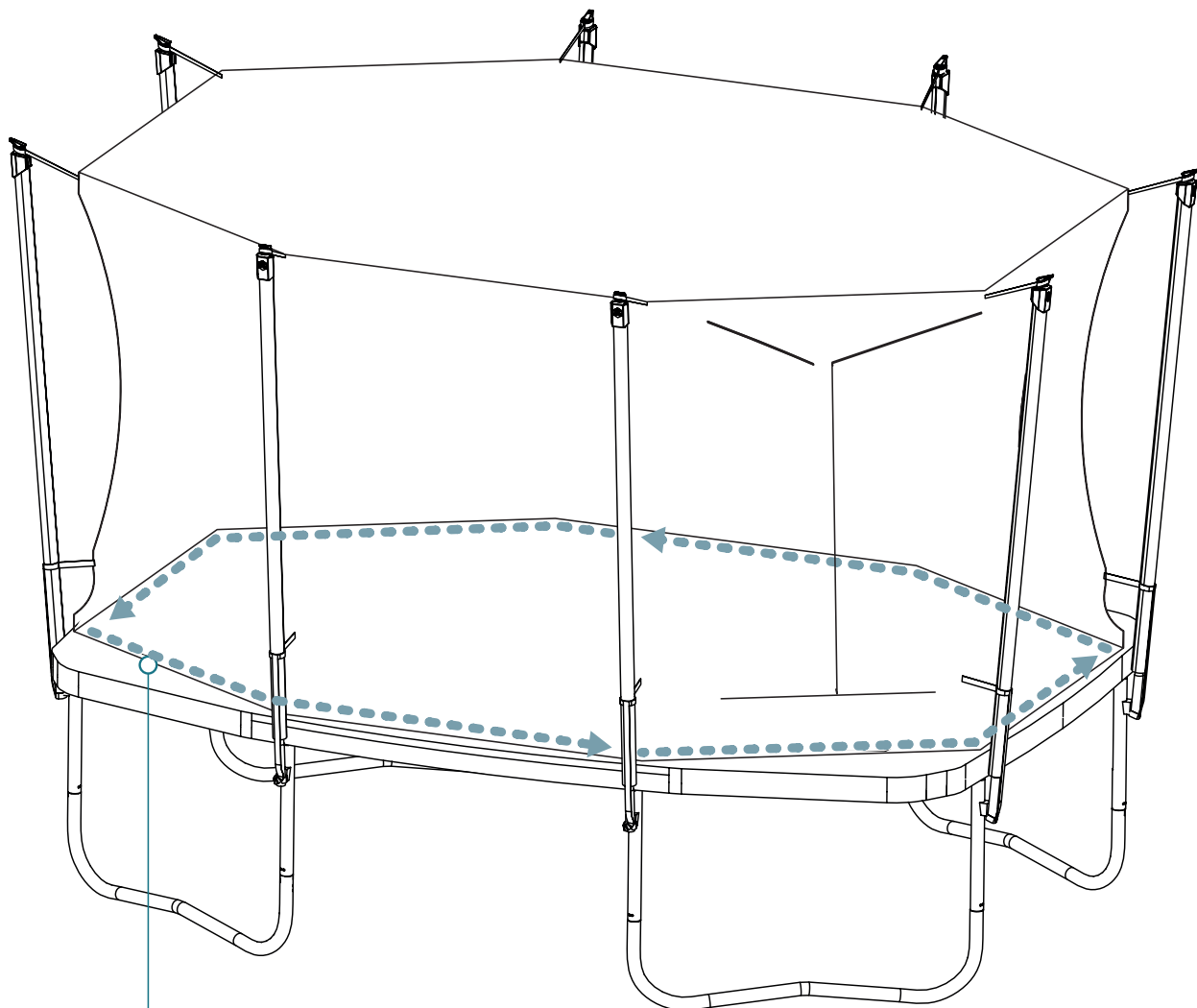

! Close the safety zipper between the net and padding.

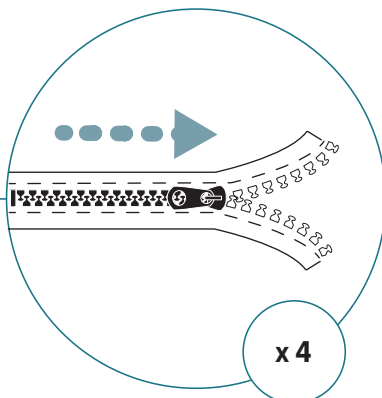

9

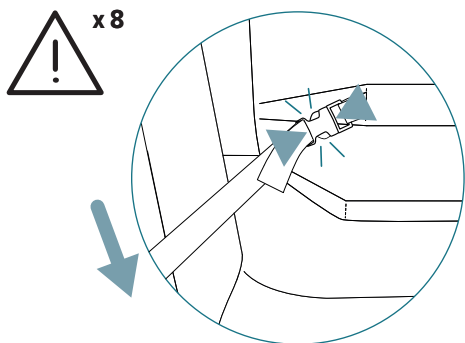

! Connect the clips and tension the safety belt straps well to keep the safety belt in position and to prevent accidents and injuries. Follow the order below.

! Make sure all clips are securely connected.

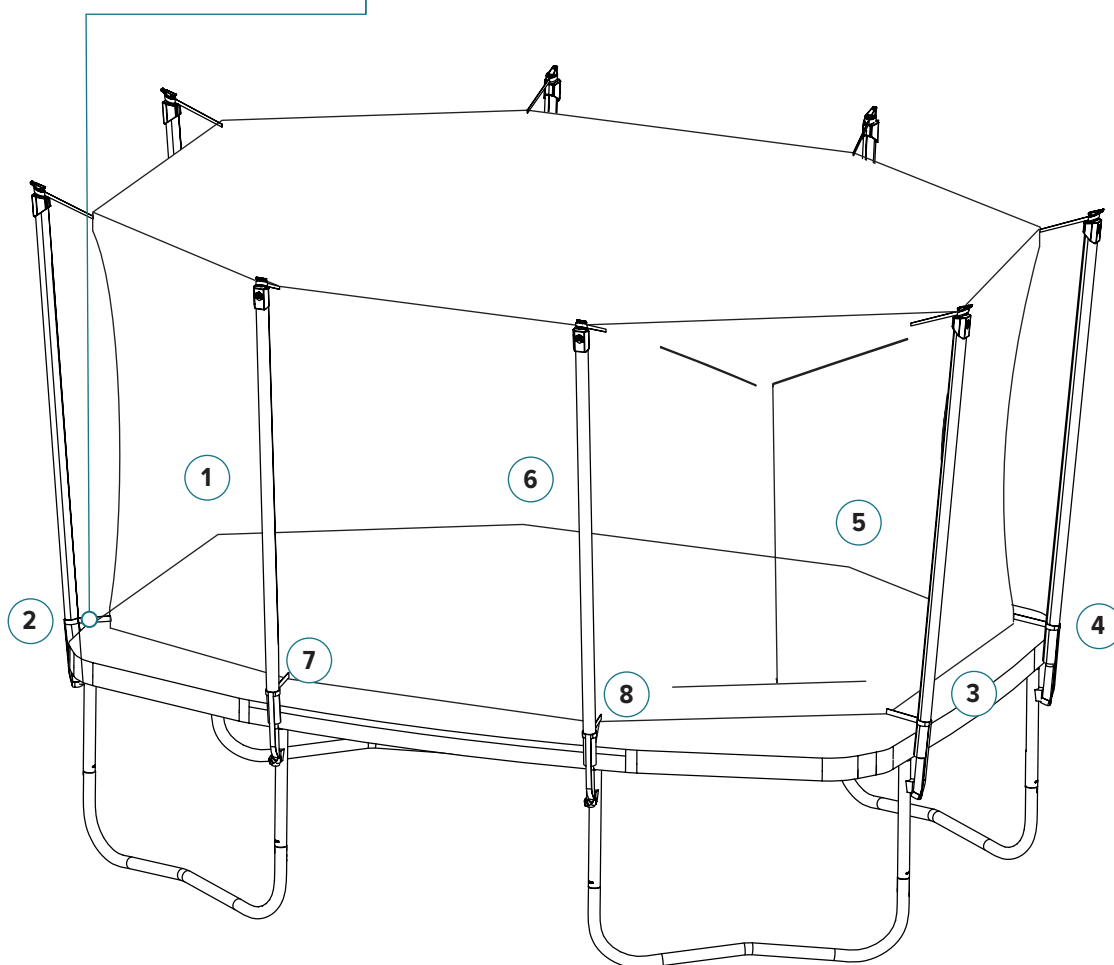

10

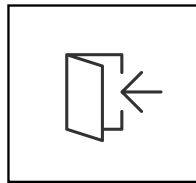
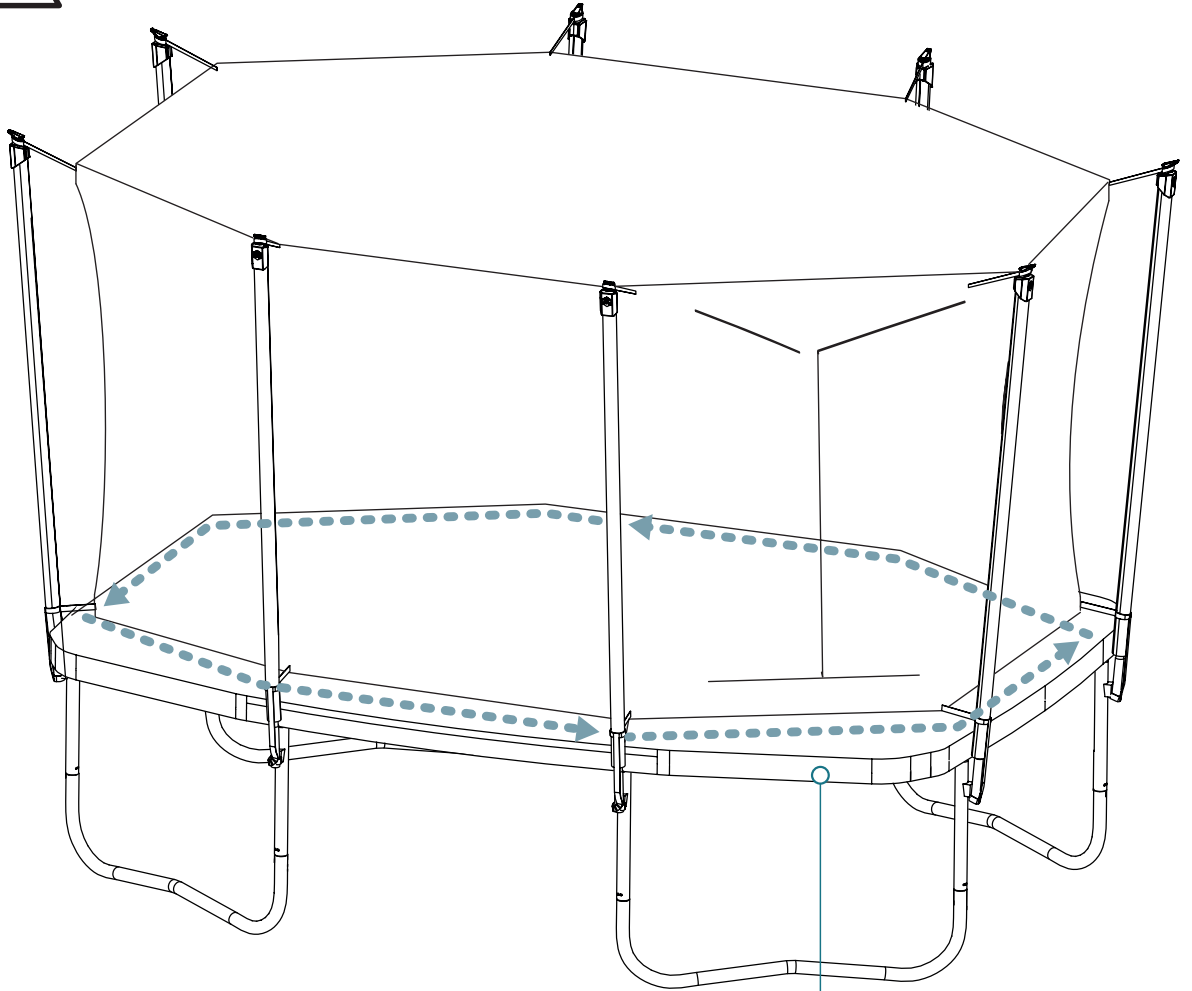

- ! Tie the warning placard on the frame so that it is clearly visible for the user to read.
- ! Check that all instructions have been followed and that all parts are securely fastened in the correct positions. If you are unsure please contact us for further guidance.

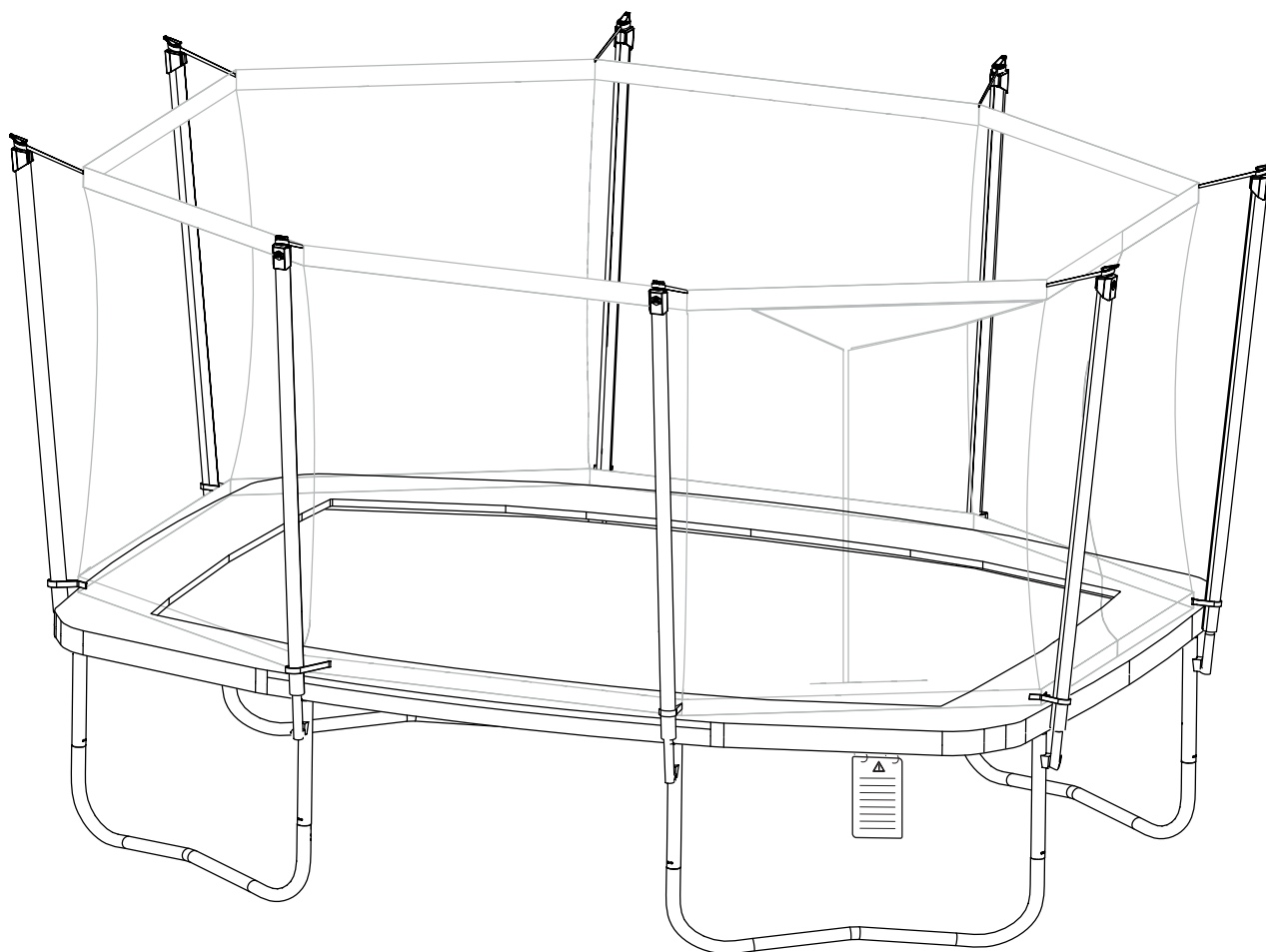

CARE & MAINTENANCE

INSPECTION

Inspect the trampoline and trampoline enclosure before each use and replace any worn, defective, or missing parts.

The following conditions could represent potential hazards:

1. Missing, improperly positioned, or insecurely attached frame padding, barrier or enclosure support system padding and pole caps.
2. Punctures, frays, tears, or holes worn in the bed or frame padding, the barrier or support system padding.
3. Deterioration in the stitching or fabric of the bed or frame padding, barrier or support system padding.
4. Ruptured springs,
5. A bent or broken frame or enclosure support system.
6. A sagging bed or barrier
7. Sharp protrusions on the frame, suspension system or enclosure support system.

Note that sunlight, rain, snow and extreme temperatures reduce the strength of these parts over time. If the above checks are not carried out the trampoline could become dangerous. Make sure to replace defective or missing parts.

To order original North Trampoline spare parts, please contact your local dealer. If any parts of the trampoline are exchanged or updated they should be installed according to the assembly manual of the trampoline. The new or added parts may have their own instructions for attachment and correct installation. Be sure to carefully follow these instructions and apply them accordingly.

INSPECTION cont.

Check all coverings of bolts for sharp edges and replace them if necessary. If self locking nuts are used it should be noted that these are suitable for only one assembly and must be replaced for reassembly.

CLEANING

When cleaning the jump mat be sure to first remove the debris with a broom. Use a garden hose and cold water to clean any remaining dirt. The padding can be wiped with mild detergent to remove dirt from seams and pockets. Make sure to clean the padding from any detergent residue. The trampoline can dry naturally in the sun.

STORAGE

During winter season the soft parts of the trampoline such as the foam pad should be kept in room temperature and away from moisture. To avoid mold make sure to dry the soft parts thoroughly before storage. Preferably, all metal parts should be stored inside for longer durability.

The trampoline should be equipped with an approved anchor set from North Trampoline to prevent displacement due to wind. In strong wind conditions always remove the safety net and jump mat. This prevents the trampoline from moving or flipping and further keeps your trampoline from damage.

To disassemble the trampoline, follow the assembly manual in reverse. As for the safety net poles, detach them from the frame but keep sleeves, protective foam and top caps still assembled. This will save you some time for the next assembly. Use gloves to protect your hands from injury during disassembly.

Replace the safety net after 3 years.

Retain these instructions for continued care and maintenance.

USE INSTRUCTIONS

WARNING

DO NOT attempt or allow somersaults on the trampoline. Landing on the head or neck can cause serious injury, paralysis, or death, even when landing in the middle of the bed.

Do not allow more than one person on the trampoline inside the trampoline enclosure. Use by more than one person at the same time can result in serious injuries.

Use trampoline and enclosure only with mature, knowledgeable supervision.

Trampolines over 20 in. (51 cm) tall are not recommended for use by children under 6 years of age.

Inspect the trampoline and enclosure before each use. Make sure the frame padding, barrier and the enclosure support system padding is correctly and securely positioned. Replace any worn, defective, or missing parts.

Climb on and off the trampoline. It is a dangerous practice to jump from the trampoline to the floor or ground when dismounting, or to jump onto the trampoline when mounting. Do not use the trampoline as a springboard to other objects.

Stop bounce by flexing knees as feet come in contact with the trampoline bed. Learn this skill before attempting others.

Learn fundamental bounces and body positions thoroughly before trying more advanced skills. A variety of trampoline activities can be carried out by performing the basic fundamentals in various series and combinations, performing one fundamental after another, with or without feet bounces between them.

WARNING cont.

Avoid bouncing too high. Stay low until bounce control and repeated landing in the center of the trampoline can be accomplished. Control is more important than height.

While keeping the head erect, focus eyes on the trampoline toward the perimeter. This will help control bounce.

Avoid bouncing when tired. Keep turns short.

Properly secure the trampoline when not in use. Protect it against unauthorized use. If a trampoline ladder is used, the supervisor should remove it from the trampoline when leaving the area to prevent unsupervised access by children under 6 years of age.

Do not use or stand near the trampoline in windy or gusty conditions. A trampoline can become airborne when exposed to sustained wind or gusting wind conditions. This can result in serious injury, paralysis, or death, as well as property damage. To reduce these risks, disassemble the trampoline and enclosure and store them until weather conditions improve. Anchoring a trampoline frame may prevent the trampoline from moving as a result of the wind, but even anchored trampolines can become airborne or damaged. Consult a qualified contractor to determine what type of anchor works best in your location.

Keep objects away which could interfere with the performer. Maintain a clear area around the trampoline.

Do not use the trampoline while under the influence of alcohol or drugs.

For additional information concerning the trampoline equipment, contact the manufacturer.

For information concerning skill training, contact a certified trampoline instructor.

WARNING cont.

Bounce only when the surface of the bed is dry. Wind or air movement should be calm to gentle. The trampoline must not be used in gusty or severe winds.

Users may become entangled in or strangled by loose cords or in gaps between trampoline and enclosure.

Keep enclosure tightly fastened to the trampoline in accordance with the manufacturer's instructions. Failure to properly assemble and maintain a tight, secure trampoline/ enclosure boundary may result in serious injury, strangulation, or death.

Do not attempt to jump over the barrier.

Do not attempt to crawl under the barrier.

Do not intentionally rebound off the barrier.

Do not hang from, kick, cut, or climb on the barrier.

Wear clothing free of drawstrings, hooks, loops or anything that could get caught while using the trampoline/enclosure and result in entanglement or strangulation, or both.

Do not attach anything to the barrier that is not a manufacturer-approved accessory or part of the enclosure system.

Enter and exit the enclosure only at the enclosure door or barrier opening designated for that purpose.

Read all instructions before using the trampoline and enclosure. Warnings and instructions for the care, maintenance, and use of this trampoline and enclosure are included to promote safe, enjoyable use of this equipment.

EXERCISES & TRICKS

Learn fundamental jumps and body positions thoroughly before trying more advanced tricks.

Note: To stop bouncing bend your knees when your feet touch the mat. Practice this technique so that you may stop safely if you lose control or land outside of the centre of the trampoline.

BASIC JUMP

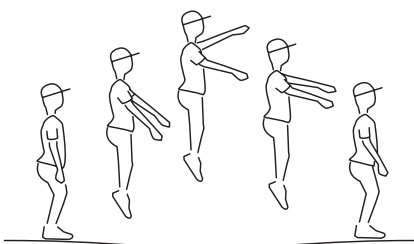

Jump with your feet together to warm up. While bouncing on a rectangular trampoline, always face one of the short ends. Stand with your feet slightly apart in the middle of the trampoline and keep your body stretched. Keep your legs together when bouncing and extend your feet. Land properly on the soles of your feet, with your feet slightly apart. Firmly push off your feet when you jump up from the trampoline. Stretch up your body and swing your arms upwards and forwards. Part your feet and bend your knees when you land, use your arms to maintain your balance.

TUCK JUMP

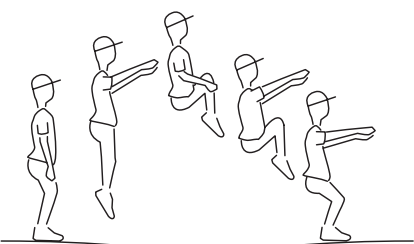

Begin in the same way as for a basic jump. Bend your knees towards your chest and place your arms gently around your legs at the highest point of the jump. Release your legs and stretch out your body before you reach the mat again. Land with your body stretched and your arms by your sides.

STRADDLE JUMP

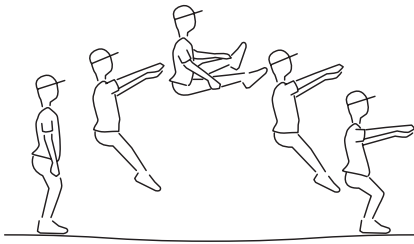

Begin in the same way as for a basic jump. Bend your body at the hips with your legs straight at the highest point of the jump. Part your legs as much as you can with your feet extended, and try to touch the top of your feet at the highest point of the jump. Land with your body stretched and your arms by your sides.

SEAT DROP

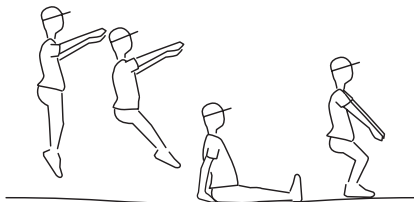

First practice the correct landing position without bouncing. Sit in the middle of the trampoline with your legs together in front of you. Lean back slightly with your back straight, place your hands a little further back and point your fingers forwards. Then try to land from a standing position to a seat drop without bouncing, and then with a slight bounce. To get back up on your feet, push your hips forward and press down with the palms of your hands. Make sure you land so that you are sitting in the centre of the trampoline, and then land on your feet in the centre of the mat.



CONTACT

North Trampoline, Inc
C/O Thorellians Associates
70 West Madison St., STE 5750
CHICAGO, IL 60602

ONLINE

info@northtrampoline.com
www.northtrampoline.com